

NEWNEX PROPRIETARY

THIS DOCUMENT AND THE DATA DISCLOSED HEREIN OR WITHIN IS NOT TO BE REPRODUCED, USED, OR DISCLOSED IN WHOLE OR PART TO ANYONE WITHOUT THE WRITTEN PERMISSION OF NEWNEX

COMPANY NAME

CUSTOMER SIGNATURE

DATE

COMMENTS:

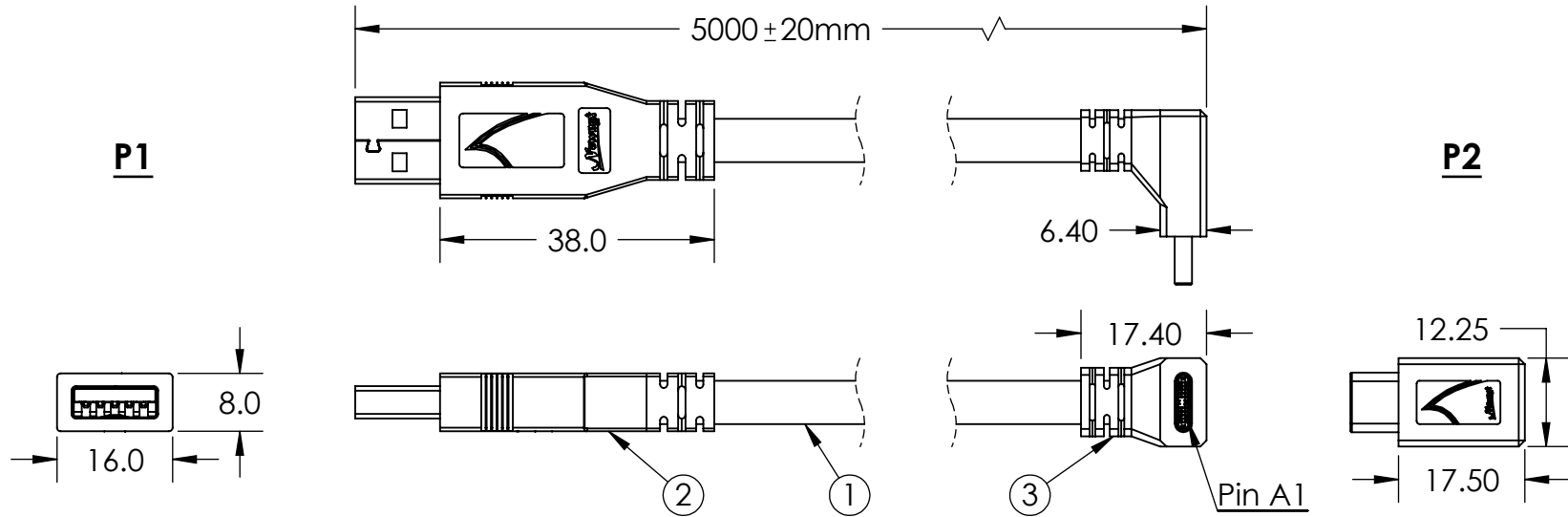

WIRING STRUCTURE		
Type C	SIGNAL NAME	A Male
A4,B4,A9,B9	VBUS	1
A5	CC	NC
A7	Dn1	2
A6	Dp1	3
A1,B1,A12,B12	GND	4,7
A3	SDPn1	5
A2	SDPp1	6
B10	SDPn2	8
B11	SDPp2	9
SHELL	Shield	SHELL

Rp=56KΩ

Notes:

1. Cable: USB 3.0 Black PVC Jacket.
2. Connector: USB 3.1 A Male.
3. Connector: USB 3.1 Type C Down Angled Male with 56k Rp.
4. Packaging: 1 Piece + PE bag.

Newnex Technology Corp.



UNLESS OTHERWISE SPECIFIED DIMENSIONS ARE IN MILLIMETERS TOLERANCES ARE:

FRACTIONS DECIMALS ANGLES
 • NA XX ± 0.2 ± 0.5
 .XX ± 0.10 ± 0.50

PROJ: TITLE: USB 3.1 A Male to Angled Type C Male, 5M, Black.

SCALE: 1:1 REV: A

DATE: 2/26/2019

DRAWN BY: XW

APPROVED BY:

PART NUMBER: U3S1A01C16-050

CHECKED BY:

SHEET 1 OF 1

*100% OPEN, SHORT, MISWIRE TESTING

*RoHS compliant product

*Both shell clam and copper foil have 360 degree contact with braiding

Drawing generated