

NEWNEX PROPRIETARY

THIS DOCUMENT AND THE DATA DISCLOSED HEREIN OR WITHIN IS NOT TO BE REPRODUCED, USED, OR DISCLOSED IN WHOLE OR PART TO ANYONE WITHOUT THE WRITTEN PERMISSION OF NEWNEX

COMPANY NAME

CUSTOMER SIGNATURE

DATE

COMMENTS:

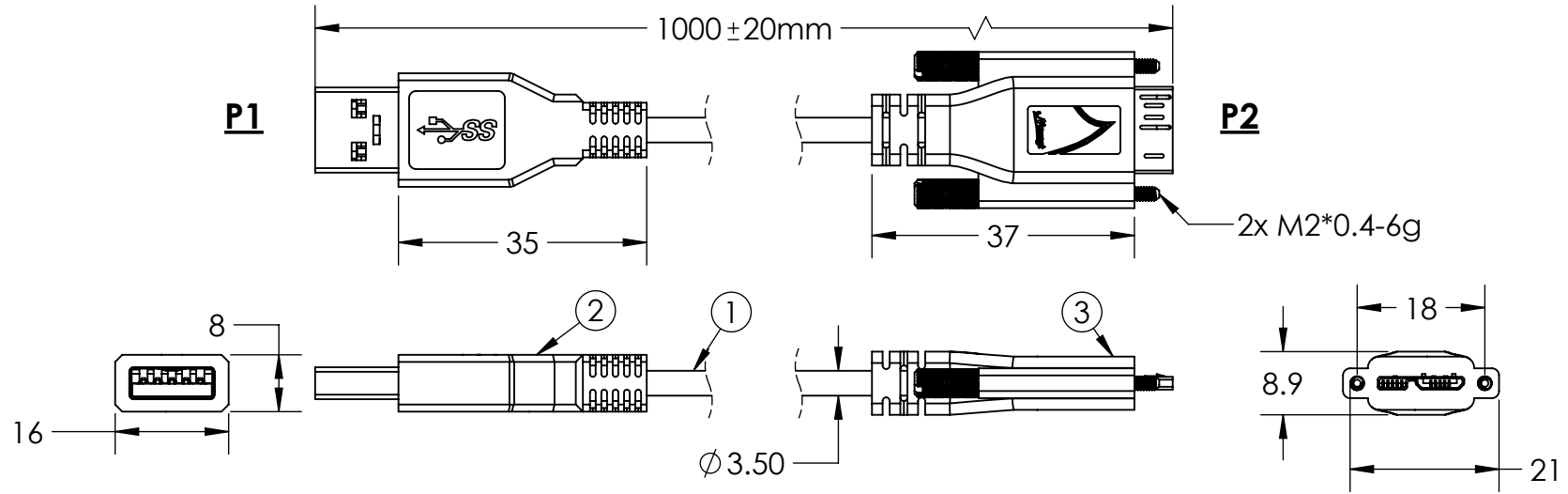

Notes:

1. **Cable:** USB 3.2 Thin Cable, OD: 3.5mm, Black. 100% Braid + extra layer shielding

2. **Connector:** USB3 A Male, with extra 360° Copper tape coverage.

3. **Connector:** USB3 Micro B Male Dual Screw Locking, with extra 360° Copper tape coverage.

4. **Packaging:** 1 Piece + PE bag.

WIRING STRUCTURE

P1	SIGNAL	P2
1	PWR	1
2	D-	2
3	D+	3
4	GND	5
5	SDP1-	6
6	SDP1+	7
7	DRAIN	8
8	SDP2-	9
9	SDP2+	10
SHELL	BRAID	SHELL

*100% OPEN, SHORT, MISWIRE TESTING

*RoHS compliant product

*Both shell clam and copper foil have 360 degree contact with braiding

Newnex Technology Corp.



UNLESS OTHERWISE SPECIFIED DIMENSIONS ARE IN MILLIMETERS TOLERANCES ARE:

FRACTIONS DECIMALS ANGLES
 ± NA X ± 0.2 ± 0.5
 XX ± 0.10
 XXX ± 0.050

PROJ: [Symbol] TITLE:

SCALE: 1:1 REV: A

DATE: 4/3/2026

Enhanced Shielding USB 3.2 Thin Cable, A Male to Micro B Male Dual Screw Locking, 1m, Black.

DRAWN BY: ZL

APPROVED BY:

PART NUMBER: U3SFAS1MCIN010

CHECKED BY:

SHEET 1 OF 1

REVISION COMMENTS: Drawing Generated.